

BECKER COM

COMMUNICATION



AR 4201 VHF-AM-Transceiver

■ This extremely small and light-weight transceiver offers 760 channels and is certified for use in VFR and IFR equipped aircraft.

Even smaller and lighter than its forerunner – the legendary AR 3201 – it is ideal for installation in gliders, motor gliders and small aircraft due to its low power requirement and 2 1/4 inch round panel cutout. Due to the implementation of the most modern technology it has been possible to minimise the depth of the module, including the connector, to less than 9 inches.

The equipment has an output of 5 – 7 Watts carrier (16 W PEP). A standby frequency and 99 memories can be easily programmed and recalled. The AR 4201 has

intercom, panel-lighting, voltage indicator, an AF-input as well as an automatic test-routine as standard functions.

Two dynamic and two standard microphones can be connected without any alterations. The clear display shows the active frequency and either the standby frequency, the memory channel used or the supply voltage and also the external temperature (with the optional temperature sensor).

This equipment is useful in a wide range of aircraft and is also optimal for use at flying schools and flying clubs, who place a lot of value on quick, safe and simple operation. ■

AR 4201 VHF-AM-Transceiver

Technical Data:

- Supply Voltage: 12.4 – 15.1 V
- Emergency Supply Voltage: 10.0 V
- Standby Current: < 70 mA
- Transmit Current: < 2.5 A

- Frequency Range: 118.000 – 136.975 MHz
- Frequency Channels: 760
- Channel Spacing: 25 kHz
- Memories: 99

- Storage Temp.: – 55 °C ... + 85 °C
- Operating Temp.: – 20 °C ... + 55 °C
- Maximum Altitude: 50000 ft

- Sensitivity: < 1.5 µV for 6 dB (S+N)/N

- Bandwith: > 8 kHz for 6 dB

- Selectivity: > 60 dB for 25 kHz
- Transmit Output: > 5 Watt Carrier
16 Watt PEP

- Audio Output: > 3 Watt into 4 Ω
- Phone Output: > 100 mW into 600 Ω
- Dynamic Mike: < 2 mV sym. into 150 Ω
- Standard Mike: > 100 mV into 100 Ω

- AF-Auxiliary Input: 1 V – 8 V into 600 Ω
- Digital-Voltmeter: 7 V – 15 V
- Digital-Thermometer (option): – 20 °C...+ 55 °C

- Certifications:

- JTSO – 2C37d, ED-23 A, Equipment Class 4
- JTSO – 2C38d, ED-23 A, Equipment Class C
- EUROCAE/RTCA ED-14C/DO-160 C
- EUROCAE/RTCA ED-12A/DO-178 A
- BZT: A 107 417 D LB
- LBA.O.10.911/87 JTSO

Operational Modes:

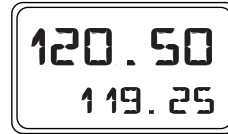

Active-Standby
Frequency



Channel

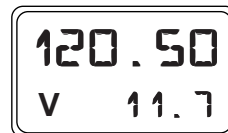

Supply Voltage

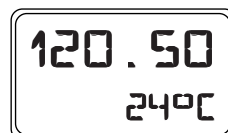

External Temperature
(optional)

Dimensions:

- Width: 61.3 mm / 2.386 inch
- Height: 61.3 mm / 2.386 inch
- Depth: 192.0 mm / 7.559 inch (229.0 mm / 9.016 inch with connector)
- Weight: 0.67 kg / 1.47 lbs

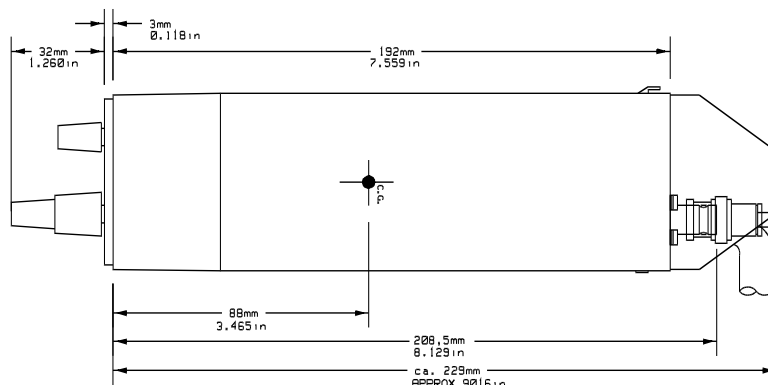
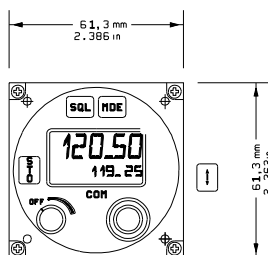

BECKER FLUGFUNKWERK GMBH
Baden Airpark B 108
77836 Rheinmünster / Germany
Phone +49 (0) 7229 / 305-0
Fax +49 (0) 7229 / 305-217
e-mail: info@becker-avionics.de
http://www.becker-avionics.de

Distributed by: